

REVISIONS				
REV.	DESCRIPTION	DATE	APPROVED	
0	INITIAL RELEASE	22/NOV/02	NST III	
1	1" DIM. INCORRECT. ADDED NOTE 5 AND 1.0" MIN DIM.	27/JAN/03	NST III	
2	ADDED PVC PIPE TO NOTE 4	18/APR/03	NST III	
3	ADDED DIM "F"	3/JUN/03	NST III	
4	ADDED DIM "G"	7/MAY/04	NST III	
5	REVISED NOTE 1 TO CLARIFY APPLICATION OF NSF RATING	10/MAY/11	SH	

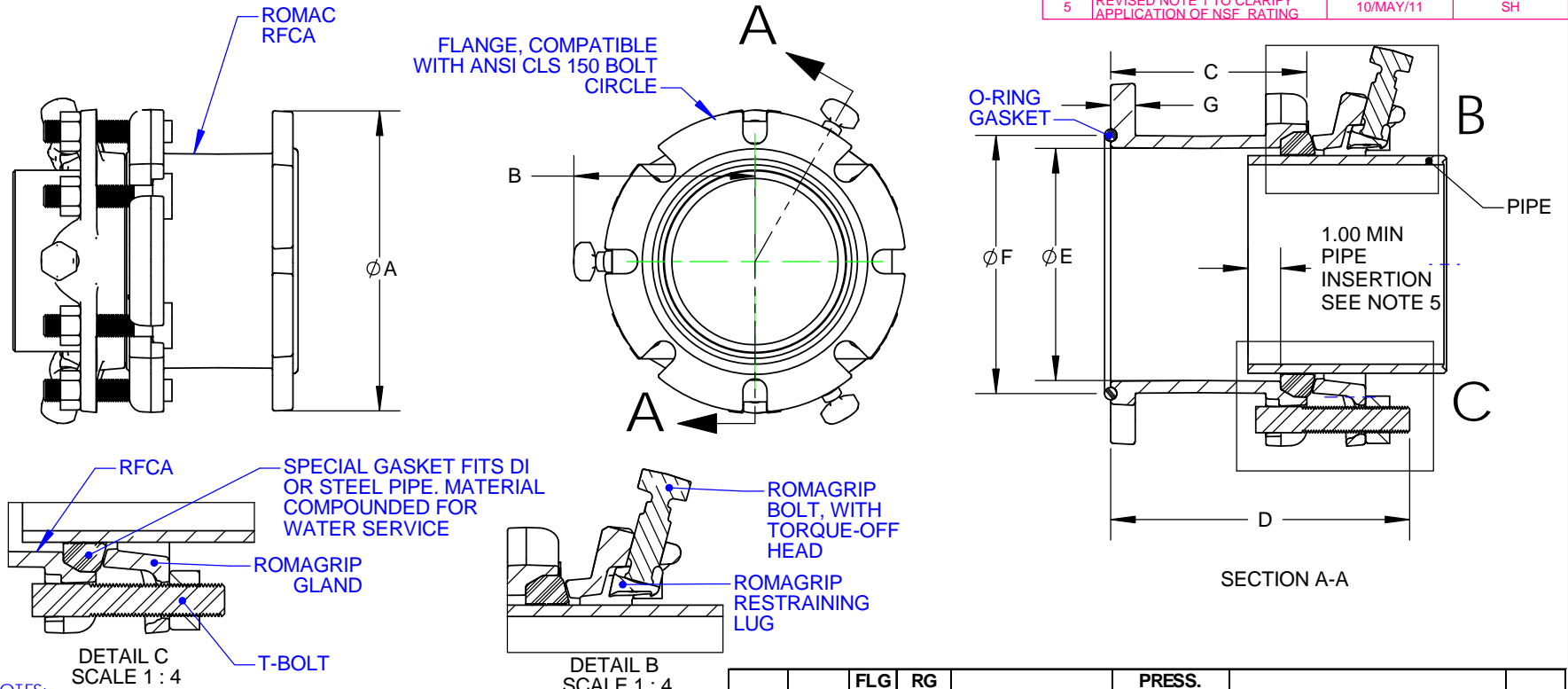

- NOTES:
1. COATING: ROMAC SHOPCOAT PAINT. NSF 61 CERTIFIED FUSION BONDED EPOXY AVAILABLE.
 2. PRESSURE RATING: SEE TABLE.
 3. DUCTILE IRON AND T-BOLTS PER AWWA C111. STAINLESS STEEL FASTENERS AVAILABLE.
 4. FOR USE WITH DUCTILE IRON PIPE, STEEL PIPE, AND PVC PIPE (A ROMAC RG-PVC RESTRAINER IS REQUIRED WHEN USED ON PVC)
 5. THE MINIMUM PIPE INSERTION IS 1.0" AT BOTH ZERO DEFLECTION AND AT MAXIMUM DEFLECTION VALUES (SEE TABLE).

NOM. SIZE	DEFL. (deg)	FLG OD A	RG MAX B	T BOLTS		PRESS. (PSIG)		DIMENSIONS					WGT, LBS	
				QTY	SIZE	LGTH	WKG	TEST	C	D	E	F		G
3	2.0	7.5	5.3	4	5/8"	3.75	275	412.5	4.88	8.00	4.04	4.66	0.75	21
4	3.5	9.0	5.7	4	3/4"	4.25	275	412.5	5.50	9.00	5.00	6.00	0.75	29
6	3.5	11.0	6.7	6	3/4"	4.25	275	412.5	6.00	9.25	7.10	7.90	0.75	40
8	3.3	13.5	7.8	6	3/4"	4.25	275	412.5	6.00	9.25	9.25	10.00	0.75	53
10	3.0	16.0	8.8	8	3/4"	4.25	275	412.5	6.75	10.25	11.30	12.40	0.75	82
12	3.0	19.0	9.9	8	3/4"	4.25	275	412.5	6.81	10.25	13.40	15.12	0.81	110

PROPRIETARY NOTICE
 THIS DRAWING CONTAINS CONFIDENTIAL PROPRIETARY INFORMATION AND IS THE PROPERTY OF ROMAC IND., INC. IT IS TO BE USED ONLY FOR THE PURPOSE FOR WHICH IT WAS SUBMITTED AND SHALL NOT HAVE IT'S INFORMATION DISCLOSED OR REPRODUCED IN WHOLE OR IN PART FOR ANY PURPOSE WITHOUT PRIOR WRITTEN PERMISSION OF ROMAC IND., INC.

UNLESS OTHERWISE SPECIFIED
 DIMENSIONS ARE IN INCHES
 TOLERANCES ARE ON:
 1 PL DECIMALS ± .060
 2 PL DECIMALS ± .030
 3 PL DECIMALS ± .010
 ANGLES ± 1°
 FRACTIONS ± 1/64

SIGNATURES
 DRAWN
 CHECKED
 APPROVAL ORGANIZATIONS
 ENGINEERING

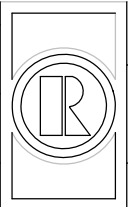

ROMAC INDUSTRIES INC.,
 BOTHELL, WA
 TITLE
 3"-12" RFCA
 RESTRAINED FLANGE
 COUPLING ADAPTER
 DWG. NO. B2111-A SIZE A REV. NO. 5 SCALE NTS SHEET 1 OF 1